

- Wide Input Voltage Range:
+8V to +25V
- Negative Output:
-2.5V/4A to -15V/1.5A
- Adjustable Output Voltage
- 85% Efficiency
- Remote Sense Capability

The PT6640 series is a positive input to negative output line of Integrated Switching Regulators (ISRs). Designed for general purpose applications, the PT6640 series delivers a negative output voltage at up to 24W. The PT6640 is packaged in a 14-Pin SIP (Single In-line Package) and is available in a surface-mount configuration.

Standard Application

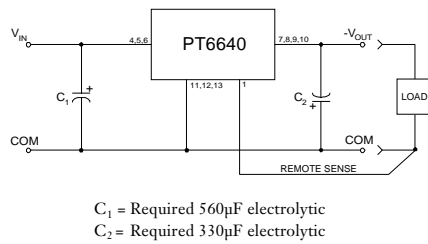

Pin-Out Information

1	Remote Sense
2	Do Not Connect
3	Do Not Connect
4	+V _{in}
5	+V _{in}
6	+V _{in}
7	-V _{out}
8	-V _{out}
9	-V _{out}
10	-V _{out}
11	GND
12	GND
13	GND
14	V _{out} Adjust

Ordering Information

PT6641	□ = -3.3 Volts
PT6642	□ = -5.0 Volts
PT6643	□ = -12.0 Volts
PT6644	□ = -9.0 Volts
PT6645	□ = -15.0 Volts
PT6646	□ = -2.5 Volts

PT Series Suffix (PT1234X)

Case/Pin Configuration	Heat Spreader
Vertical Through-Hole	P
Horizontal Through-Hole	D
Horizontal Surface Mount	E

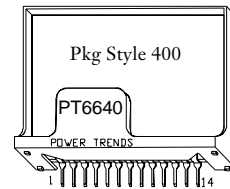

Note: Back surface of product is conducting metal

Specifications

Characteristics (T _a = 25°C unless noted)	Symbols	Conditions	PT6640 SERIES			Units	
			Min	Typ	Max		
Output Current	I _o	T _a = 60°C, 200 LFM, pkg P T _a = 25°C, natural convection	0.1 0.1 0.1 0.1 0.1	— — — — —	(See Note 2) 4.0 2.5 2.0 1.5	A	
Input Voltage Range	V _{in}	0.1A ≤ I _o ≤ I _o max V _o = -2.5V/3.3V V _o = -5.0V V _o = -9.0V V _o = -12.0V V _o = -15.0V	+8 +8 +8 +8 +8	— — — — —	+27 +25 +21 +18 +15	V	
Output Voltage Tolerance	ΔV _o	Over V _{in} range T _a = -40°C to +65°C	V _o -0.1	—	V _o +0.1	V	
Output Voltage Adjust Range	V _{oadj}	Pin 14 to V _o or ground V _o = -2.5V V _o = -3.3V V _o = -5.0V V _o = -9.0V V _o = -12.0V V _o = -15.0V	-1.8 -2.2 -3.0 -6.0 -9.0 -10.0	— — — — — —	-4.3 -4.7 -6.5 -10.2 -13.6 -17.0	V	
Line Regulation	Reg _{line}	+9V ≤ V _{in} ≤ +V _{in} max, I _o = I _o max	—	±0.5	±1.0	%V _o	
Load Regulation	Reg _{load}	V _{in} = +12V, 0.1 ≤ I _o ≤ I _o max	—	±0.5	±1.0	%V _o	
V _o Ripple/Noise	V _n	V _{in} = +12V, I _o = I _o max	—	3.0	—	%V _o	
Transient Response with C ₂ = 330 μ F	t _{tr} V _{os}	I _o step between 0.5xI _o max and I _o max V _o over/undershoot	— —	200 100	— —	μ Sec mV	
Efficiency	η	V _{in} = +12V, I _o = 0.5x I _o max	V _o = -2.5V V _o = -3.3V V _o = -5.0V V _o = -9.0/12.0V V _o = -15.0V	— — — — —	75 79 83 85 84	— — — — —	%
		V _{in} = +12V, I _o = I _o max	V _o = -2.5V V _o = -3.3V V _o = -5.0V V _o = -9.0/12.0/15.0V	— — — —	74 77 80 84	— — — —	%

Continued

PT6640 Series

24W 12V Input Positive to Negative Voltage Converter

Specifications (continued)

Characteristics ($T_a = 25^\circ\text{C}$ unless noted)	Symbols	Conditions	PT6640 SERIES			Units
			Min	Typ	Max	
Switching Frequency	f_o	$+9\text{V} \leq V_{in} \leq V_{in,max}$ Over I_o range	500	550	600	kHz
Absolute Maximum Operating Temperature Range	T_a	Over V_{in} range	-40	—	+85 ⁽²⁾	$^\circ\text{C}$
Storage Temperature	T_s	—	-40	—	+125	$^\circ\text{C}$
Mechanical Shock	—	Per Mil-STD-883D, Method 2002.3	—	500	—	G's
Mechanical Vibration	—	Per Mil-STD-883D, Method 2007.2, 20-2000 Hz, soldered in a PC board	—	7.5	—	G's
Weight	—	—	—	14	—	grams

Notes: (1) The PT6640 Series requires a 330 μF (output) and 560 μF (input) electrolytic capacitors for proper operation in all applications.
(2) See Safe Operating Area curves or call the factory for guidance on thermal derating.

TYPICAL CHARACTERISTICS

Characteristic Curves @12.0V V_{in} (See Note A)

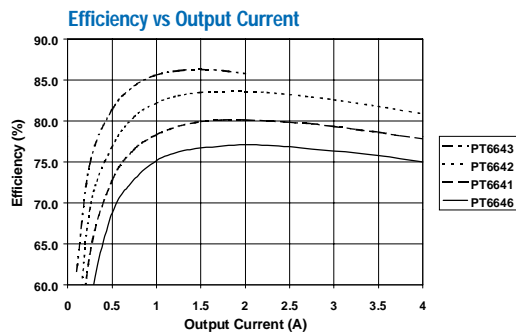

Safe Operating Area Curves (See Note B)

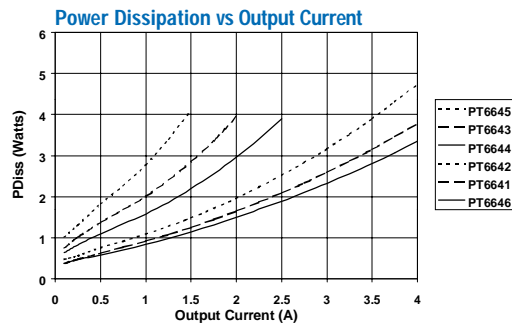
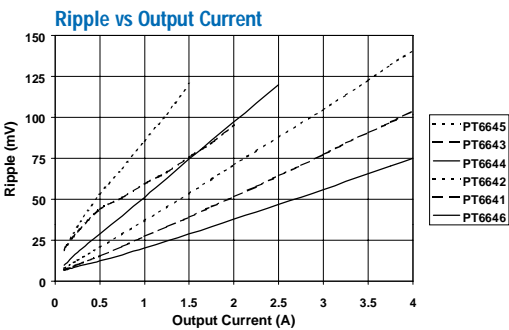
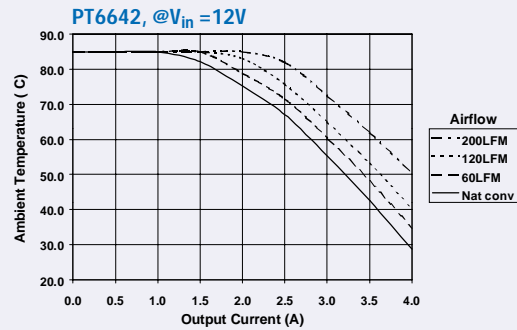

Note A: Characteristic data has been developed from actual products tested at 25°C. This data is considered typical data for the DC-DC Converter.

Note B: SOA curves represent operating conditions at which internal components are at or below manufacturer's maximum rated operating temperatures.

Adjusting the Output Voltage of the PT6640 24W Positive to Negative ISR Series

The negative output voltage of the Power Trends PT6640 series ISRs may be adjusted higher or lower than the factory trimmed pre-set voltage with the addition of a single external resistor. Table 1 gives the allowable adjustment range for each model in the series as V_a (min) and V_a (max).

Adjust Up: An increase in the negative output voltage is obtained by adding a resistor R2, between pin 14 (V_o adjust) and pins 7-10 ($-V_o$).

Adjust Down: Adding a resistor (R1), between pin 14 (V_o adjust) and pins 11-13 (GND), decreases the output voltage magnitude.

Refer to Figure 1 and Table 2 for both the placement and value of the required resistor, either (R1) or R2 as appropriate.

Notes:

1. Use only a single 1% resistor in either the (R1) or R2 location. Place the resistor as close to the ISR as possible.
2. Never connect capacitors from V_o adjust to either GND, V_{out} , or the Remote Sense pin. Any capacitance added to the V_o adjust pin will affect the stability of the ISR.
3. If the Remote Sense feature is being used, connecting the resistor (R1) between pin 14 (V_o adjust) and pin 1 (Remote Sense) can benefit load regulation.
4. The maximum allowed input voltage (V_{in}) will change as V_{out} is adjusted. The difference between the input voltage (V_{in}) and the output voltage (V_{out}) must not exceed 30V or $10 \times V_{out}$, whichever is less. Use one of the following formulas to determine the maximum allowed input voltage for the PT6640.

$$\begin{aligned} &|V_{out}| \text{ greater than } 2.73V, \\ V_{in}(\text{max}) &= 30 - |V_{out}| \quad \text{Vdc} \end{aligned}$$

For example, if $V_{out} = -12V$,

$$V_{in}(\text{max}) = 30 - |-12| = 18Vdc$$

$$\begin{aligned} &|V_{out}| \text{ less than } 2.73V, \\ V_{in}(\text{max}) &= 10 \times |V_{out}| \quad \text{Vdc} \end{aligned}$$

Figure 1

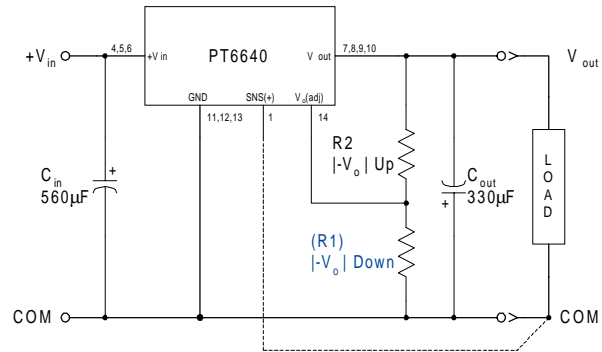

The values of (R1) [adjust down], and R2 [adjust up], can also be calculated using the following formulas.

$$(R1) = \frac{R_o (V_o - 1.25)(V_a - 1.25)}{1.25 (V_o - V_a)} - R_s \quad k\Omega$$

$$R2 = \frac{R_o (V_o - 1.25)}{V_a - V_o} - R_s \quad k\Omega$$

Where: V_o = Original V_{out} (magnitude)
 V_a = Adjusted V_{out} (magnitude)
 R_o = The resistance value in Table 1
 R_s = The series resistance from Table 1

Table 1

PT6640 ADJUSTMENT AND FORMULA PARAMETERS

Series Pt #	PT6646	PT6641	PT6642	PT6644	PT6643	PT6645
V_o (nom)	-2.5V	-3.3V	-5.0V	-9.0V	-12.0V	-15.0V
V_a (min)	-1.8V	-2.2V	-3.0V	-6.0V	-9.0V	-10.0V
V_a (max)	-4.3V	-4.7V	-6.5V	-10.2V	-13.6V	-17.0V
R_o (k Ω)	4.99	4.22	2.49	2.0	2.0	2.0
R_s (k Ω)	2.49	4.99	4.99	12.7	12.7	12.7

PT6640 Series

Table 2

PT6640 ADJUSTMENT RESISTOR VALUES

Series Pt #	PT6646	PT6641	PT6642	Series Pt #	PT6644	PT6643	PT6645
Current	4Adc	4Adc	4Adc	Current	2.5Adc	2Adc	1.5Adc
V ₀ (nom)	-2.5Vdc	-3.3Vdc	-5.0Vdc	V ₀ (nom)	-9.0Vdc	-12.0Vdc	-15.0Vdc
V _a (req'd)				V _a (req'd)			
-1.8	(1.4)kΩ			-6.0	(6.9)kΩ		
-1.9	(2.9)kΩ			-6.2	(9.2)kΩ		
-2.0	(5.0)kΩ			-6.4	(11.9)kΩ		
-2.1	(8.1)kΩ			-6.6	(14.0)kΩ		
-2.2	(13.3)kΩ	(1.0)kΩ		-6.8	(18.6)kΩ		
-2.3	(23.7)kΩ	(2.3)kΩ		-7.0	(23.0)kΩ		
-2.4	(54.9)kΩ	(3.9)kΩ		-7.2	(28.3)kΩ		
-2.5		(5.8)kΩ		-7.4	(35.0)kΩ		
-2.6	59.9kΩ	(8.4)kΩ		-7.6	(43.5)kΩ		
-2.7	28.7kΩ	(11.7)kΩ		-7.8	(55.0)kΩ		
-2.8	18.3kΩ	(16.5)kΩ		-8.0	(71.0)kΩ		
-2.9	13.1kΩ	(23.6)kΩ		-8.2	(95.0)kΩ		
-3.0	10.0kΩ	(35.4)kΩ	(1.6)kΩ	-8.4	(135.0)kΩ		
-3.1	7.9kΩ	(59.0)kΩ	(2.3)kΩ	-8.6	(215.0)kΩ		
-3.2	6.4kΩ	(130.0)kΩ	(3.1)kΩ	-8.8	(455.0)kΩ		
-3.3	5.3kΩ		(4.0)kΩ	-9.0		(31.7)kΩ	
-3.4	4.4kΩ	81.5kΩ	(5.1)kΩ	-9.2	64.8kΩ	(36.1)kΩ	
-3.5	3.8kΩ	38.3kΩ	(6.2)kΩ	-9.4	26.1kΩ	(41.2)kΩ	
-3.6	3.2kΩ	23.8kΩ	(7.6)kΩ	-9.6	13.1kΩ	(47.1)kΩ	
-3.7	2.7kΩ	16.6kΩ	(9.1)kΩ	-9.8	6.7kΩ	(54.1)kΩ	
-3.8	2.3kΩ	12.3kΩ	(10.9)kΩ	-10.0	2.8kΩ	(62.6)kΩ	(25.8)kΩ
-3.9	2.0kΩ	9.4kΩ	(13.0)kΩ	-10.2	0.2kΩ	(72.8)kΩ	(28.3)kΩ
-4.0	1.7kΩ	7.4kΩ	(15.6)kΩ	-10.4		(85.7)kΩ	(31.1)kΩ
-4.1	1.4kΩ	5.8kΩ	(18.7)kΩ	-10.6		(102.0)kΩ	(34.1)kΩ
-4.2	1.2kΩ	4.6kΩ	(22.6)kΩ	-10.8		(124.0)kΩ	(37.3)kΩ
-4.3	1.0kΩ	3.7kΩ	(27.6)kΩ	-11.0		(155.0)kΩ	(40.9)kΩ
-4.4		2.9kΩ	(34.2)kΩ	-11.2		(201.0)kΩ	(44.9)kΩ
-4.5		2.2kΩ	(43.6)kΩ	-11.4		(278.0)kΩ	(49.3)kΩ
-4.6		1.7kΩ	(57.6)kΩ	-11.6		(432.0)kΩ	(54.3)kΩ
-4.7		1.2kΩ	(80.9)kΩ	-11.8		(895.0)kΩ	(59.8)kΩ
-4.8			(128.0)kΩ	-12.0			(66.1)kΩ
-4.9			(268.0)kΩ	-12.2		94.8kΩ	(73.3)kΩ
-5.0				-12.4		41.1kΩ	(81.6)kΩ
-5.1			88.4kΩ	-12.6		23.1kΩ	(91.3)kΩ
-5.2			41.7kΩ	-12.8		14.2kΩ	(103.0)kΩ
-5.3			26.1kΩ	-13.0		8.8kΩ	(117.0)kΩ
-5.4			18.4kΩ	-13.2		5.2kΩ	(133.0)kΩ
-5.5			13.7kΩ	-13.4		2.7kΩ	(154.0)kΩ
-5.6			10.6kΩ	-13.6		0.7kΩ	(181.0)kΩ
-5.7			8.4kΩ	-13.8			(217.0)kΩ
-5.8			6.7kΩ	-14.0			(268.0)kΩ
-5.9			5.4kΩ	-14.2			(343.0)kΩ
-6.0			4.4kΩ	-14.5			(570.0)kΩ
-6.1			3.5kΩ	-15.0			
-6.2			2.8kΩ	-15.5			42.3kΩ
-6.3			2.2kΩ	-16.0			14.8kΩ
-6.4			1.7kΩ	-16.5			5.6kΩ
-6.5			1.2kΩ	-17.0			1.1kΩ

R1 = (Blue) R2 = Black